

Master
主机

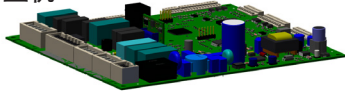

Slave
从机

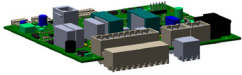

STUURAUTOMAAT MASTER of SLAVE FS/WHBC
CONTROL UNIT MASTER or SLAVE FS/WHBC
FEUERUNGSAUTOMAT MASTER oder SLAVE FS/WHBC
UNITÉ DE CONTROL MASTER ou SLAVE FS/WHBC
UNITÀ DI CONTROLLO MASTER o SLAVE FS/WHBC
控制单元主机或从机说明书/商用壁挂炉适用

NL: **Montagevolgorde**

De verschijningsvorm kan per type verschillen.

GB: **Assembly order**

The appearance may differ per type.

D: **Montageauftrag**

Der Ausführung kann je nach Typ unterschiedlich sein.

F: **Ordre de montage**

L'apparence peut différer selon le type.

I: **Ordine di assemblaggio**

L'aspetto può differire per tipo.

CN: **安装顺序**

每台机器的外观可能会不完全相同

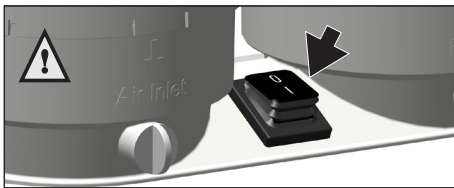

Schakel het toestel uit door middel van de hoofdschakelaar.

Switch off the device by means of the main switch.

Schalten Sie das Gerät am Hauptschalter aus.

Éteignez l'appareil avec l'interrupteur principal.

Spegner il dispositivo con l'interruttore principale.

按下开关，关闭电源

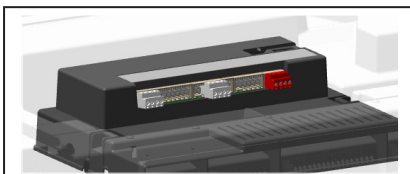
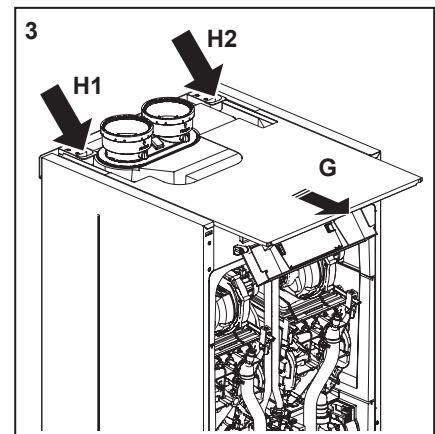
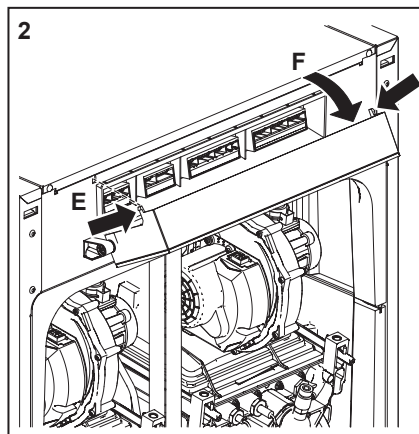
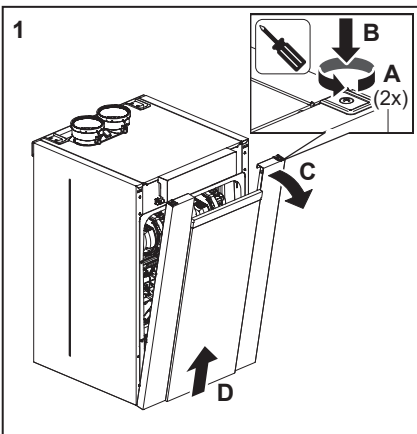

- * Accessoire. Indien aanwezig.
- * Accessory. When present.
- * Zubehör. Wann anwesend.
- * Accessoire. Si disponibile.
- * Accessorio. Se disponibile.
- * 附件，如果配置了的话

1. Verwijder de voorzijde van de mantel.

Remove the front panel.

Entfernen Sie die Vorderseite der Verkleidung.

Retirez le devant de la manteau.

Rimuovere la parte anteriore della mantello.

移除前面板

2. Draai de bedieningsunit naar beneden.

Turn the display unit downwards.

Drehen Sie die Bedienungseinheit nach unten.

Tournez l'unité de commande vers le bas.

Ruotare l'unità di controllo verso il basso.

把前面板按图示方法扳至显示面朝下

3. Verwijder de bovenzijde van de mantel.

Remove the top panel.

Entfernen Sie die Oberseite der Verkleidung.

Retirez le haut partie de la manteau.

Rimuovi la parte superiore della mantello.

移除顶板

4. Neem Clip In-module* en de bovenzijde van de besturingskast weg.

Remove the Clip In-module* and the top side of the control unit.

Entfernen Sie der Clip In-Modul und die Oberseite des Steuerkastens.

Retirez la Module Clip In et le haut du boîtier de commande.

Rimuovere la Modulo Clip In e la parte superiore della scatola di controllo.

移除扩展插件*和顶部的控制单元

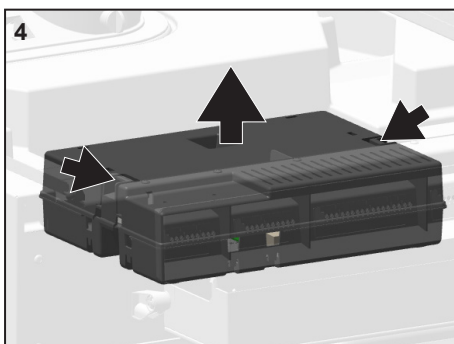

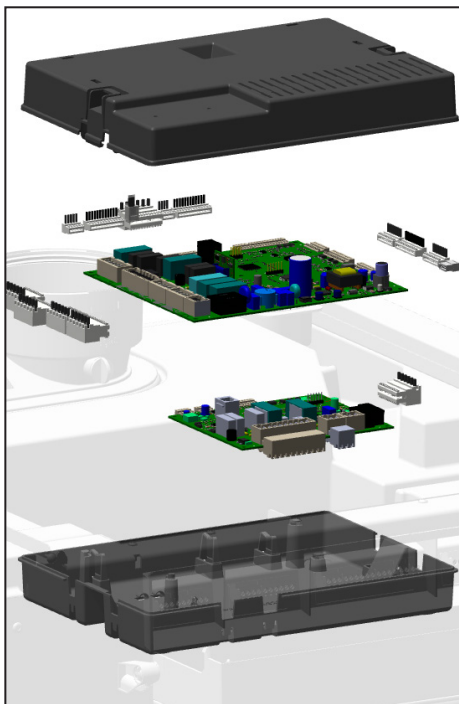

5. Verwijder alle stekkers van de printplaat en verwijder de printplaat. Indien de SLAVE-stuurautomaat vervangen moet worden, verwijder dan ook van de onderste printplaat alle stekkers en verwijder de printplaat.

Remove all connectors from the PCB and remove the PCB. When the SLAVE control unit has to be exchanged remove also all connectors from the lowest PCB and remove the PCB.

Entfernen Sie alle Stecker von der Platine und entfernen Sie die Platine weg. Wenn der SLAVE-Feuerungsautomat ausgetauscht werden muss, entfernen Sie auch alle Stecker von der unteren Platine und entfernen Sie die Platine.

Retirez toutes les fiches de la carte de circuit imprimé et retirez la carte de circuit imprimé. Si le pilote automatique SLAVE doit être remplacé, retirez également toutes les fiches de la carte de circuit imprimé inférieure et retirez la carte de circuit imprimé.

Rimuovere tutte le spine dal circuito e rimuovere il circuito. Se è necessario sostituire l'autopilota SLAVE, rimuovere anche tutte le spine dal circuito inferiore e rimuovere il circuito.

从电路板上移除所有连接器，并移除电路板。当从机控制单元必须更换时，也要从最低的电路板上移除所有连接器，并移除电路板。

6. Plaats de nieuwe printplaat en sluit alle stekkers weer aan op de juiste posities. Vergeet niet de 2 aparte connectoren boven op de MASTER-stuurautomaat! Bouw alle onderdelen weer terug.

Insert the new PCB and reconnect all plugs in the correct positions. Don't forget the 2 separate connectors on top of the MASTER PCB! Re-assemble all parts.

Setzen Sie die neue Platine ein und schließen Sie alle Stecker wieder an den richtigen Positionen an. Vergessen Sie nicht die 2 separaten Anschlüsse oben am MASTER-Platine! Alle Teile wieder zusammenbauen.

Insérez la nouvelle carte de circuit imprimé et reconnectez toutes les fiches dans les positions correctes. N'oubliez pas les 2 connecteurs séparés sur le dessus de la carte de circuit imprimé MASTER! Remontez toutes les pièces.

Inserire la nuova scheda e ricollegare tutte le spine nelle posizioni corrette. Non dimenticare i 2 connettori separati sulla parte superiore della scheda MASTER! Riassemblare tutte le parti.

插入新的电路板，并将所有插头重新连接在正确的位置。不要忘记主电路板上的2个单独的连接器!重新组装的所有部分。

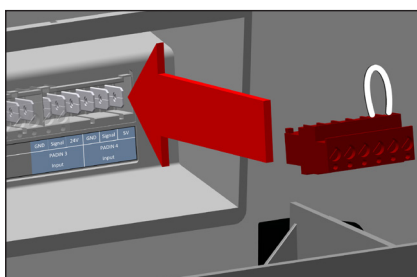
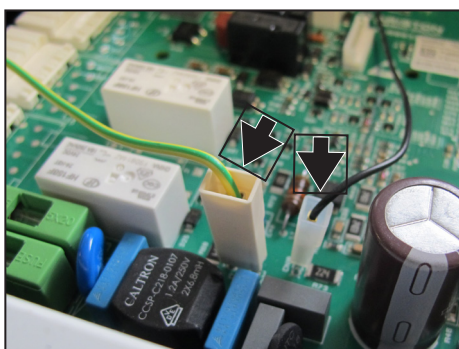

! LET OP: Indien een nieuwe Master printplaat geplaatst wordt in een ketel van vóór 2021 (tot P210450459, zie typeplaat) houdt rekening met het volgende: **Neem de connector met de brug (deel van leveringsomvang) en plaats deze op aansluiting PADIN 4 (niet indien hier BOILER LOCK staat).**

! NOTE: If a new Master-PCB is used in a boiler produced before January 2021 (until P210450459, see type plate) please take note of the following: **Take connector with bridge (part of delivery) and connect it to PADIN 4 (not if it shows BOILER LOCK).**

! HINWEIS: Wenn eine neue Master-Leiterplatte in einem vor Januar 2021 hergestellten Kessel verwendet wird (bis P210450459, siehe Typenschild), beachten Sie bitte Folgendes: **Nehmen Sie den Stecker mit Brücke (Teil der Lieferung) und schließen Sie ihn an PADIN 4 an (nicht wenn es zeigt BOILER LOCK).**

! REMARQUE: Si un nouveau Master-PCB est utilisé dans une chaudière produite avant janvier 2021 (jusqu'à P210450459, voir plaque signalétique), veuillez tenir compte des points suivants: **Prenez le connecteur avec pont (partie de la livraison) et connectez-le au PADIN 4 (pas s'indique BOILER LOCK).**

! NOTA: Se una nuova Master-PCB viene utilizzata in una caldaia prodotta prima di gennaio 2021 (fino a P210450459, vedi targhetta), si prega di prendere nota di quanto segue: **Prendere il connettore con ponte (parte della consegna) e collegarlo a PADIN 4 (non se indica BOILER LOCK).**

! 注意:如果在2021年1月之前生产的锅炉(至P210450459, 见铭牌)使用了新的主控板, 请注意以下事项:取下带有桥接(发货部分)的连接器, 并将其连接到PADIN4(如果显示为锅炉锁则不需要)。

Volg nauwkeurig de instellingen vanaf pagina 3
Follow the adjustments precise from page 5
Befolgen Sie sorgfältig die Einstellungen ab Seite 7

Suivez attentivement les paramètres de la page 9
Seguire attentamente le impostazioni da pagina 11
具体见第13页

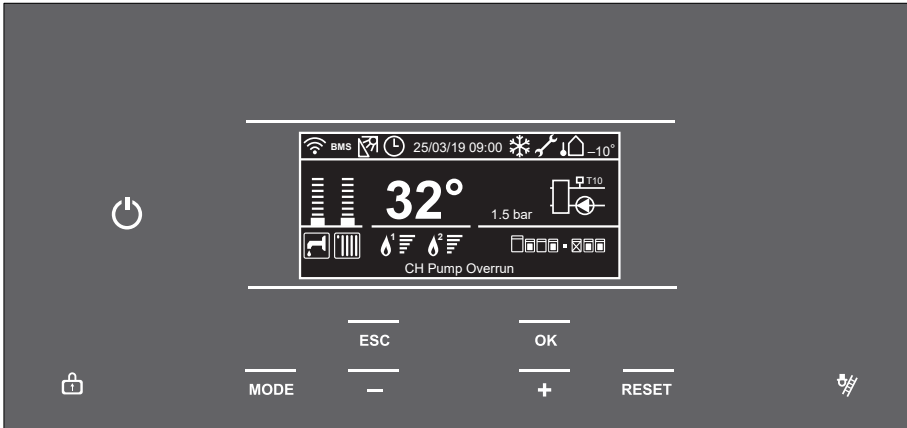

- Aan/Uit-knop
- Display vergrendelen/ontgrendelen
- MODE** Modus
- ESC** Escape/Terug/Correctie
- Waarde verminderen/omlaag/links
- Waarde vermeerderen/omhoog/rechts
- OK** Selectie bevestigen
- RESET** Reset
- Schoorsteenvegermodus

7. Schakel de voedingsspanning weer in; Wanneer een ketel wordt geactiveerd, verschijnt een vraag zoals in de afbeelding. Nadat u op OK drukt, verschijnt het volgende menu.

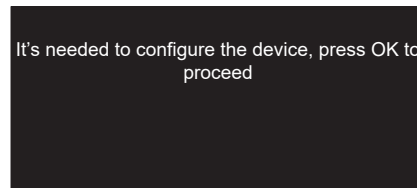

Instelling voor één ketel

Wanneer er geen sprake is van een cascade, selecteert u "Single boiler (Eén ketel)". Het systeem zal automatisch alle benodigde parameters voor één enkele ketel laden; is er een dubbele warmtewisselaar, dan wordt de warmtewisselaar automatisch ingesteld.

Instelling voor cascade

Als de ketel deel uitmaakt van een cascade-opstelling, selecteert u "Master boiler + cascade (Masterketel + cascade)" en bevestigt u deze selectie door op OK te drukken. Er wordt u dan gevraagd om het apparaat te configureren als een master- of slave-eenheid en het adres te configureren.

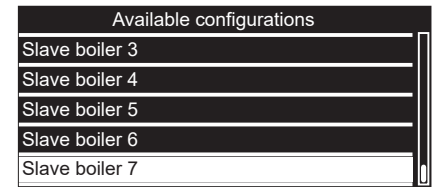
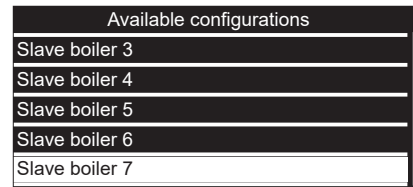
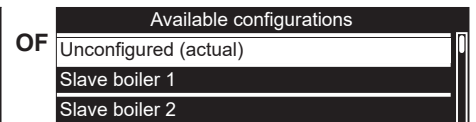
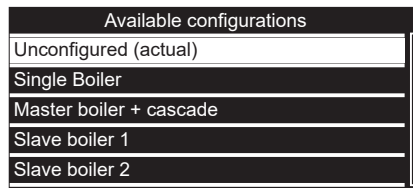

Indien alle opties beschikbaar zijn.

Alternatief
Indien Master niet meer beschikbaar is (reeds op andere ketel geconfigureerd)

- Het display toont de opstartprocedure:
 - Herkenning apparaat
 - Initialiseren;



- Het display toont vervolgens het automatisch ontluichtingsprogramma; *Bij standaard display: Indien een clip-in-module is geplaatst start het automatisch ontluichtingsprogramma na ca. 60 seconden in verband met het initialiseren van eventueel aangesloten driewegkleppen.*

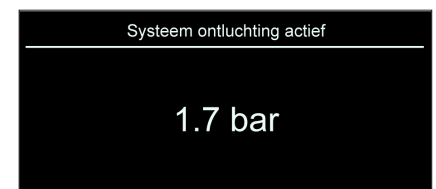

Indien een nieuwe SLAVE stuurautomaat is geplaatst, is de ketel direct bedrijfsklaar.

Indien een nieuwe MASTER stuurautomaat is geplaatst moeten de parameters uit het display naar de stuurautomaat gekopieerd worden. Volg de onderstaande procedure:

8. Houdt de **display-vergrendeltoets** 5 seconden ingedrukt.



Het display toont:

NB: ketel PCB = stuurautomaat
opslagmedium = display



NB: De stuurautomaat kent een 'slaap-modus', indien binnen bepaalde tijd geen toets wordt bediend. Activeren vindt plaats door een willekeurige toets bediening.

9. Selecteer COPY door op de **OK toets** te drukken. De parameters worden gekopieerd en het display toont achtereenvolgens:
- Data Copy
 - OK
 - Standaard weergave;

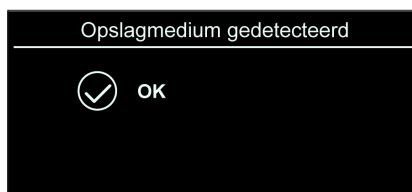

10. Hierna volgt automatisch een reset van het toestel. Het display toont nogmaals de opstartprocedure:
- Herkenning apparaat
 - Initialiseren;



- Het display toont vervolgens het automatisch ontluichtingsprogramma; *Bij standaard display: Indien een clip-in-module is geplaatst start het automatisch ontluichtingsprogramma na ca. 60 seconden in verband met het initialiseren van eventueel aangesloten driewegkleppen.*

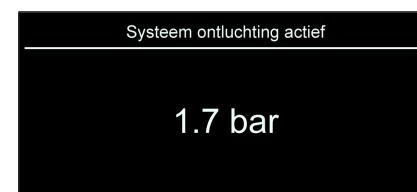

- Het display toont:

11. Selecteer BACK UP door middel van de **+toets**;

- Het display toont:

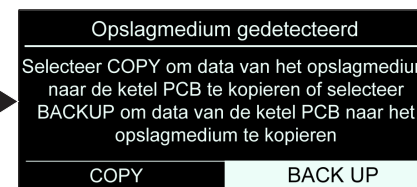
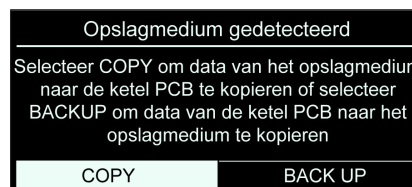

12. Druk op de **OK toets**. De parameters worden nu terug gekopieerd en het display toont achtereenvolgens:

- Data Backup
- OK
- Standaard weergave;

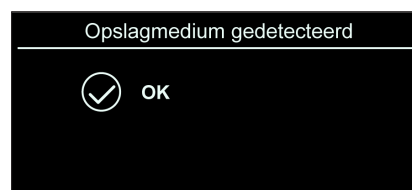

De ketel is nu bedrijfsklaar.

13. Controleer het toestel op juist functioneren;
14. Plaats de mantel terug.
15. Breng de 2 borgschroeven weer aan.

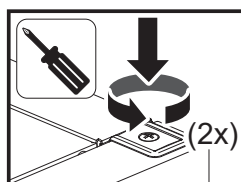





Plaats na (onderhouds-)werkzaamheden altijd de mantel terug en borg de mantel met de 2 schroeven.



LET OP: Indien een nieuwe Master printplaat geplaatst wordt in een ketel van vóór 2021 (tot P210450459, zie typeplaat) houdt rekening met het volgende:

- Een drukschakelaar en warmtevraagblokkering op PADIN 1 zijn nu voor volledige cascade.**
Parameter conditie: 24.6.4 ingesteld op 6 Branderblokkage of 7 Gasdrukschakelaar.
Vereiste actie: Indien alle ketels in cascade zijn voorzien van een drukschakelaar en / of warmtevraagblokkering dienen deze bij alle ketels te worden verwijderd indien de printplaat op de master ketel wordt vervangen. Als alternatief moet de verbinding niet worden gemaakt op de PADIN 1 maar op een van de andere PADIN's (2/3/4).
- De aansturing van de 3-wegklep in warmwater-modus (alleen als ketel ingesteld is op "boiler mode") is gewijzigd.**
Parameter conditie: 24.5.3 ingesteld op 1 Ext. tank met NTC sensor of 2 Ext. tank met thermostaat.
Vereiste actie: Verwissel aansluiting L en L1 op de 3-wegklep.

Description of the keyboard

-  On/Off-key
-  Display lock/unlock
- MODE** Modus
- ESC** Escape/Back/Correction
-  Value decrease/low/left
-  Value increase/up/right
- OK** Confirmation selection
- RESET** Reset
-  Chimney sweep function

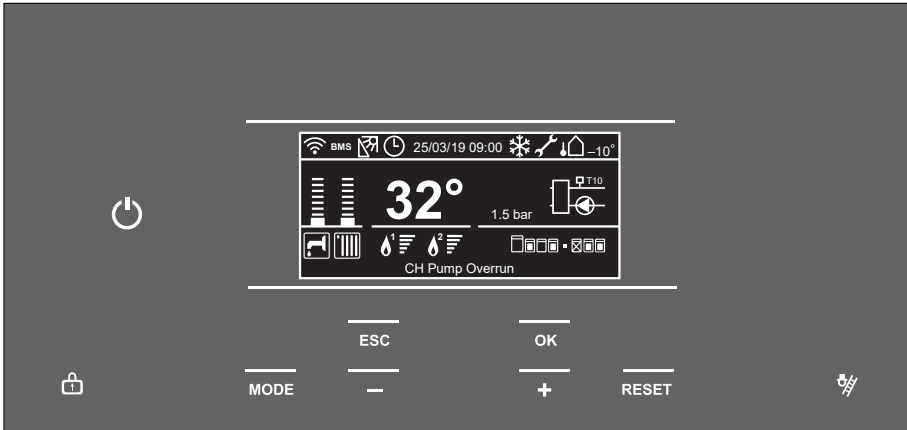

- Switch on mains power;
When a boiler is activated there is a question as in the picture.
After pressing OK the next menu is shown.

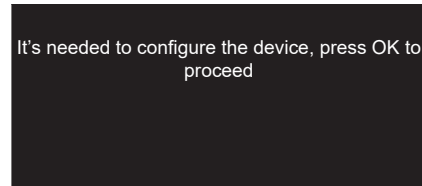

Single boiler setting

When there is no cascade, select "Single boiler". The system will automatically load all needed parameters for a single boiler; if it is a double engine the engine will automatically set.

Cascade Setting

If the boiler is part of a cascade installation, select "Master boiler + cascade" and confirm the selection by pressing the OK button. You will then be prompted to configure the appliance as either a master or slave unit and configure the address.

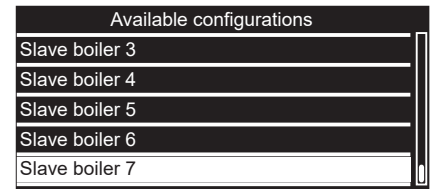
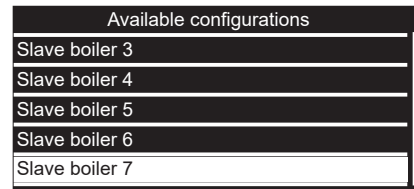
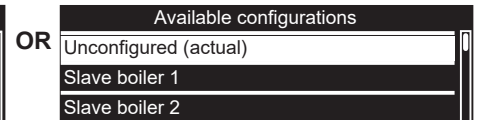
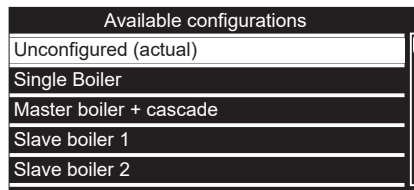

In case all options are available

Alternative
In case Master is no longer available (already configured in another boiler)

- The screen shows the start-up procedure:
 - Device discovery
 - Initialising;
- The screen shows thereafter the automatic air purge program;
At standard display: When a clip-in module is present the automatic air purge program starts after about 60 seconds in connection of initializing the possible connected three way valves.



When a **new SLAVE control unit** is placed, the boiler is directly ready to put in to operation.

When a **new MASTER control unit** is placed the parameters from the display should be copied to the control unit.
Follow next procedure:

- Press the **display-lock key** for 5 seconds.



The screen shows:

Note: Mainboard = control unit
Flash Memory = display

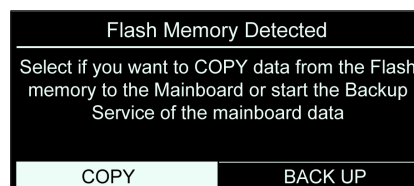

Note: The control unit has a 'sleep mode' when within a certain time no keys has been touched. Re-activating is done touching a random key.

9. Select COPY by pressing the OK key.
The parameters are being copied and the screen shows:
- Data Copy
 - OK
 - Standard screen;

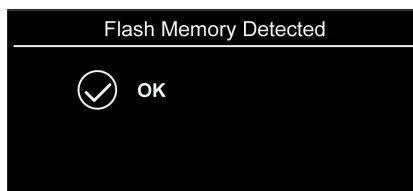
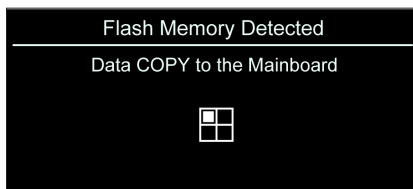

10. After this there is an automatic reset of the boiler and the screen will again show the start-up procedure:
- Device discovery
 - Initialising;

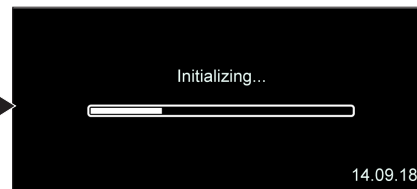

- The display shows thereafter the automatic air purge program;
At standard display: When a clip-in module is present the automatic air purge program starts after about 60 seconds in connection of initializing the possible connected three way valves.



- The screen shows:

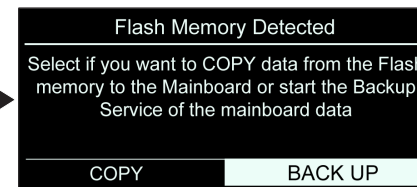
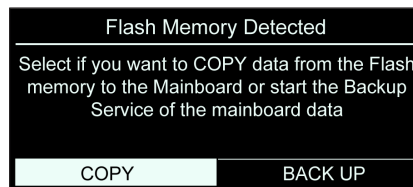

11. Select BACK UP by turning the **+-key**;

- The screen shows:

12. Press the OK button. The parameters are now copied back and the screen shows:
- Data Backup
 - OK
 - Standard screen;

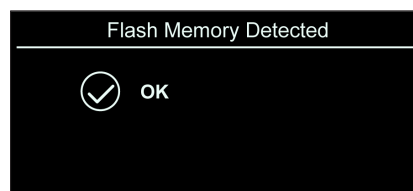
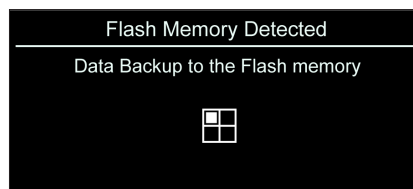

The boiler is now ready to be put in to operation.

13. Check if the boiler is working properly;
14. Put the cover back on the boiler.
15. Put back the 2 screws.

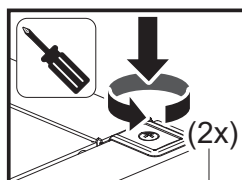





After working on the boiler always put back the cover and tighten with the 2 screws.

NOTE: If a new Master-PCB is used in a boiler produced before January 2021 (until P210450459, see type plate) please take note of the following:

- One pressure switch and heat demand lock on PADIN 1 are now for complete cascade.**
Parameter condition: 24.6.4 set to 6 Heat generation lock or 7 Gas pressure switch.
Necessary action: In case all boilers in cascade are provided with pressure switch and/or heat demand lock, these have to be removed on all boilers in case the PCB on Master boiler is exchanged. As alternative the connection should not be made on the PADIN 1 but on one of the other PADIN's (2/3/4).
- The management of the 3 way valve in DHW mode (only if boiler set to "boiler mode") has been changed.**
Parameter condition: 24.5.3 set to 1 Storage with NTC or 2 Storage with Thermostat.
Necessary action: Exchange wires L and L1 of 3-way valve.

Beschreibung der Tasten

-  Ein/Aus-Taste
-  Bildschirm blockieren/ deblockieren
- MODE** Modus
- ESC** Escape/Zurück/Korrektion
-  Wertminderen/nach unten/nach links
-  Wertsteigerung/nach oben/ nach rechts
- OK** Bestätigung Selektion
- RESET** Reset
-  Schornsteinfegerfunktion

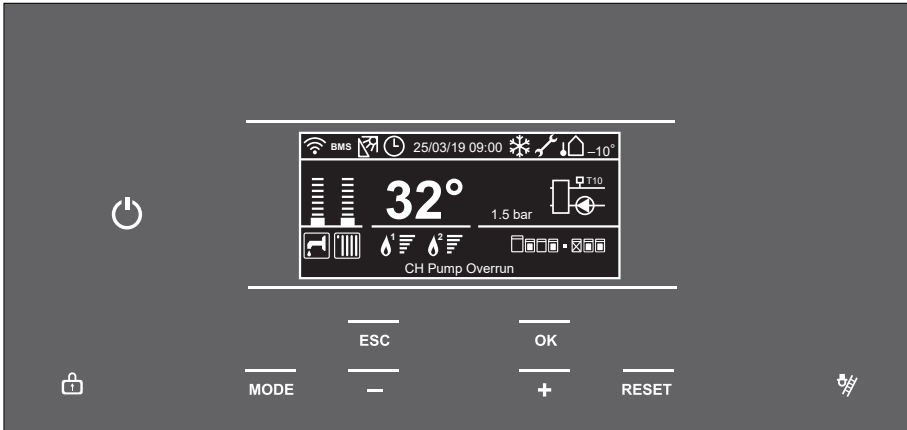

7. Schalten Sie den Strom wieder ein; Wenn ein Heizkessel in Betrieb genommen wird, wird die auf der Abbildung dargestellte Frage angezeigt. Nach dem Drücken von OK wird das nächste Menü angezeigt.

It's needed to configure the device, press OK to proceed

Einstellung einzelner Heizkessel

Wenn keine Kaskade vorhanden ist, muss „Single boiler (Einzelner Heizkessel)“ gewählt werden. Das System lädt automatisch alle erforderlichen Parameter für einen einzelnen Heizkessel. Wenn ein Doppelwärmetauscher vorhanden ist, wird dies automatisch eingestellt.

Kaskadeneinstellung

Wenn der Heizkessel Teil einer Kaskadenanlage ist, müssen „Master boiler + cascade (Master-Heizkessel + Kaskade)“ gewählt und die Auswahl durch Drücken der OK-Taste bestätigt werden. Der Benutzer wird dann aufgefordert, das Gerät entweder als Master- oder als Slave-Einheit zu konfigurieren und die Adresse einzustellen.

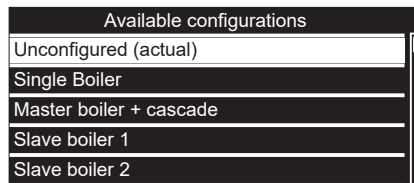

Oder

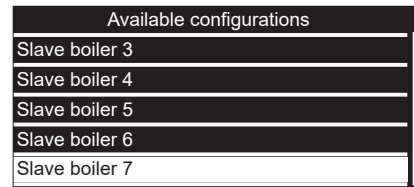
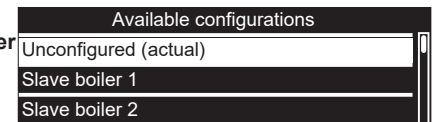

Falls alle Optionen verfügbar sind

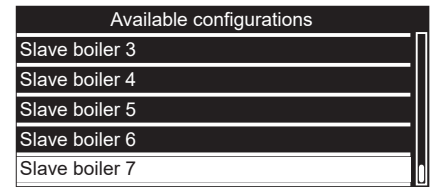

Alternative
Falls der Master nicht mehr verfügbar ist (bereits in einem anderen Kessel konfiguriert)

- Der Bildschirm zeigt:
 - Vorrichtungserkennung
 - Initialisierung;
- Der Bildschirm zeigt jetzt: Entlüftung aktiv; *Bei Standardanzeige: Wenn ein Clip-In-Modul vorhanden ist, startet das automatische Entlüftungsprogramm nach ca. 60 Sekunden, um die möglichen angeschlossenen Dreiwegeventile zu initialisieren.*

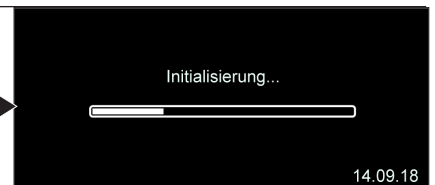

Wenn eine **neue SLAVE-Feuerungsautomat** eingesetzt wird, ist der Kessel direkt betriebsbereit.

Wenn eine **neue MASTER-Feuerungsautomat** platziert wird, sollten die Parameter von das Display in die Feuerungsautomat kopiert werden. Befolgen Sie das nächste Verfahren:

8. Drücken Sie die **Bildschirm-blockierungstaste** für 5 Sekunden.



Der Bildschirm zeigt:

Note: Platine = Feuerungsautomat
Flash-Speicher = Display

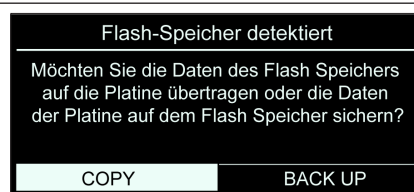

Hinweis: Die Steuereinheit verfügt über einen Schlafmodus, wenn innerhalb einer bestimmten Zeit keine Tasten berührt wurden. Die erneute Aktivierung erfolgt durch Berühren einer zufälligen Taste.

9. Wählen Sie COPY durch das Drücken der OK-Taste. Die Parameter werden jetzt kopiert und der Bildschirm zeigt:
- Daten kopieren
 - OK
 - Standard Anzeige;

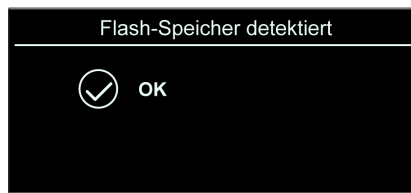
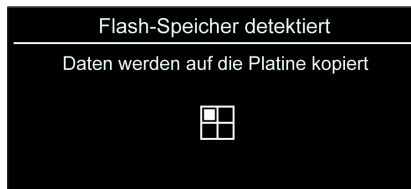

10. Jetzt folgt ein automatischer RESET des Kessels. Der Bildschirm zeigt erneut das Aufstartprozedere:
- Vorrichtungserkennung
 - Initialisierung;
 - Der Bildschirm zeigt jetzt: Entlüftung aktiv; *Bei Standardanzeige: Wenn ein Clip-In-Modul vorhanden ist, startet das automatische Entlüftungsprogramm nach ca. 60 Sekunden, um die möglichen angeschlossenen Dreiwegeventile zu initialisieren.*

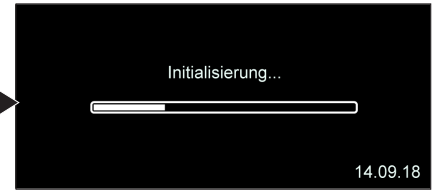

- Der Bildschirm zeigt:

11. Wählen Sie BACKUP durch das Drehen der +-Taste;

- Der Bildschirm zeigt:

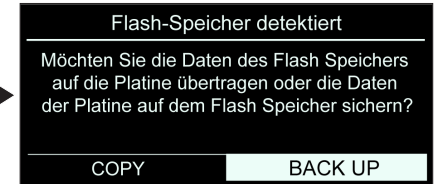
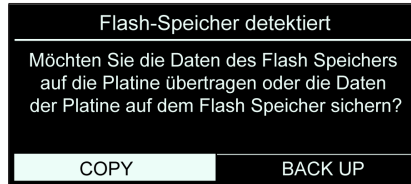

12. Drücken Sie die OK-Taste. Jetzt werden die Parameter zurück kopiert und der Bildschirm zeigt nacheinander:
- Datensicherung
 - OK
 - Standard Anzeige

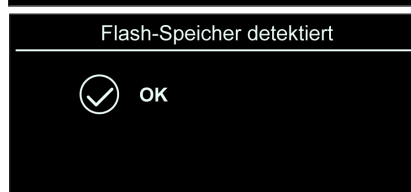
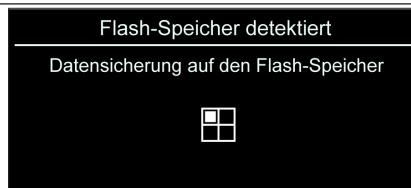

Der Kessel kann jetzt wieder in Betrieb genommen werden.

13. Kontrollieren Sie, ob der Kessel fehlerfrei arbeitet;

14. Montieren Sie die Haube.

15. Drehen Sie die 2 Schrauben zurück in die Haube.

Nach Abschluss der Arbeiten am Kessel immer die Haube montieren und mit den Schrauben befestigen.

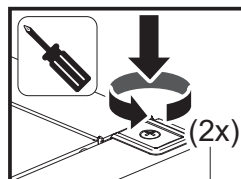

HINWEIS: Wenn eine neue Master-Leiterplatte in einem vor Januar 2021 hergestellten Kessel verwendet wird (bis P210450459, siehe Typenschild), beachten Sie bitte Folgendes:

1. **Ein Druckschalter und eine Wärmebedarfssperre an PADIN 1 sind jetzt für eine vollständige Kaskade vorgesehen.**

Parameterbedingung: 24.6.4 auf 6 Erzeugersperre oder 7 Gasdruckwächter eingestellt.





Notwendige Maßnahme: Falls alle Kessel in der Kaskade mit einem Druckschalter und / oder einer Wärmebedarfsverriegelung ausgestattet sind, müssen diese bei allen Kesseln entfernt werden, falls die Leiterplatte am Hauptkessel ausgetauscht wird. Alternativ sollte die Verbindung nicht auf dem PADIN 1, sondern auf einem der anderen PADINs (2/3/4) hergestellt werden.

2. **Die Verwaltung des 3-Wege-Ventils im Warmwassermodus (nur wenn der Kessel auf „Kesselmodus“ eingestellt ist) wurde geändert.**

Parameterbedingung: 24.5.3 auf 1 Speicher mit NTC-Fühler oder 2 Speicher mit Thermostat eingestellt.

Notwendige Maßnahme: Die Drähte L und L1 des 3-Wege-Ventils austauschen.

Description des touches

-  Touche marche / arrêt
-  Verrouillage / déverrouillage de l'écran
- MODE** Modus
- ESC** Escape / Back / Correction
-  Diminution de la valeur / bas / gauche
-  Augmentation de la valeur / haut / droite
- OK** Sélection de confirmation
- RESET** Réinitialiser
-  Fonction ramoneur

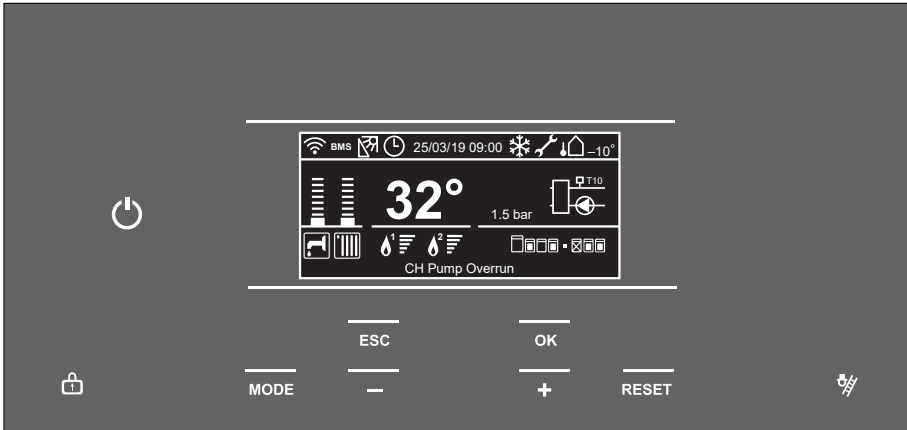

7. Branchez la tension d'alimentation ;
Lors de l'activation de la chaudière, une question apparaît comme sur l'image.
Après avoir appuyé sur OK, le menu suivant s'affiche.

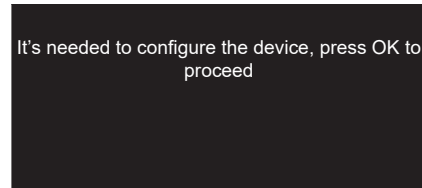

Réglage d'une chaudière simple

En l'absence de cascade, sélectionnez « Single boiler » (Chaudière simple). Le système chargera automatiquement tous les paramètres nécessaires pour une chaudière simple ; s'il s'agit d'un moteur double, le moteur sera automatiquement réglé.

Réglage de la cascade

Si la chaudière fait partie d'une installation en cascade, sélectionnez « Master boiler + cascade » (Chaudière principale + cascade) et confirmez la sélection en appuyant sur le bouton OK. Vous serez alors invité à configurer l'appareil en tant qu'unité maître ou esclave et à configurer l'adresse.

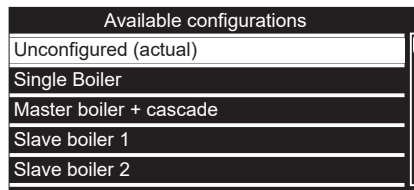

OU

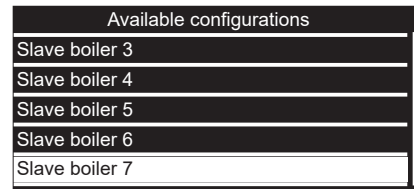
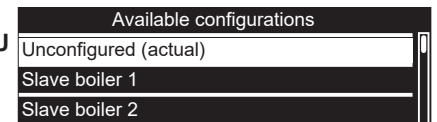

Si toutes les options sont disponibles

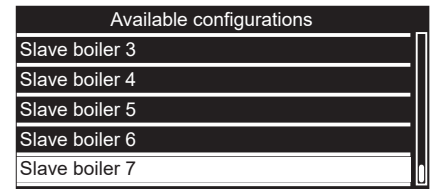

Alternative

Dans le cas où Master n'est plus disponible (déjà configuré dans une autre chaudière)

- L'écran affiche la procédure de démarrage :
 - Reconnaissance périphérique(s)
 - Initialisation ;
- L'écran affiche le programme de purge automatique ;
À l'affichage standard: *Lorsqu'un module clip-in est présent, le programme de purge d'air automatique démarre après environ 60 secondes en relation avec l'initialisation des éventuelles vannes à trois voies connectées.*

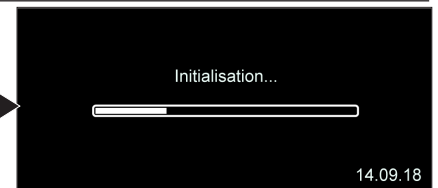
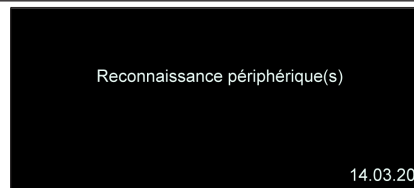

Lorsqu'une nouvelle unité de contrôle SLAVE est placée, la chaudière est directement prête à être mise en service.

Lorsqu'une nouvelle unité de contrôle MASTER est placée, les paramètres de l'affichage doivent être copiés sur l'unité de contrôle. Suivez la procédure suivante :

8. Appuyez sur le bouton **verrouillage de l'écran** pendant 5 secondes.



L'écran indique :

Remarque: carte principale = unité de contrôle
Memoire Flash = l'affichage

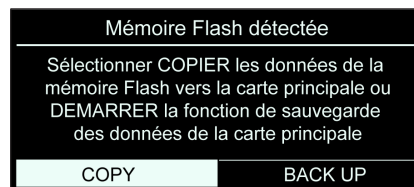

Remarque : L'unité de contrôle a un « mode veille » lorsque dans un certain temps aucune touche n'a été touchée. La réactivation se fait en touchant une touche aléatoire.

9. À l'aide du bouton OK, sélectionnez COPY.
Les paramètres sont copiés et l'affichage indique tour à tour :
- Data Copy
 - OK
 - Affichage standard ;

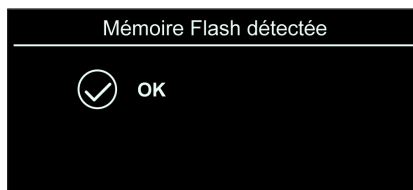
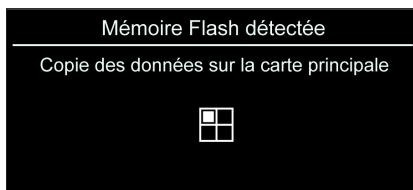

10. Ceci est suivi par une réinitialisation automatique de l'appareil. L'écran affiche à nouveau la procédure de démarrage :
- Reconnaissance périphérique(s)
 - Initialisation ;
- L'écran affiche le programme de purge automatique ;
À l'affichage standard: Lorsqu'un module clip-in est présent, le programme de purge d'air automatique démarre après environ 60 secondes en relation avec l'initialisation des éventuelles vannes à trois voies connectées.

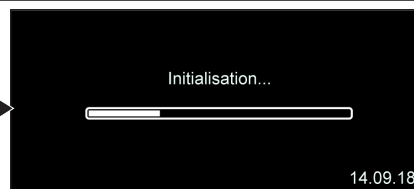
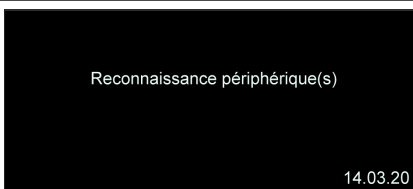

- L'écran indique :

11. À l'aide du bouton +, sélectionnez BACK UP ;

- L'écran indique :

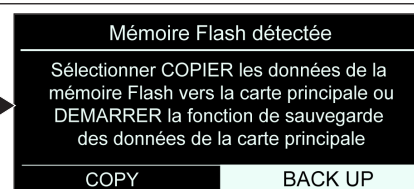

12. Appuyez sur le bouton OK. Les paramètres sont maintenant recopiés et l'affichage indique tour à tour :
- Sauvegarde de données
 - OK
 - Affichage standard ;

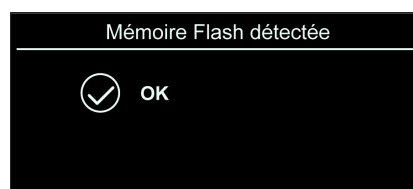
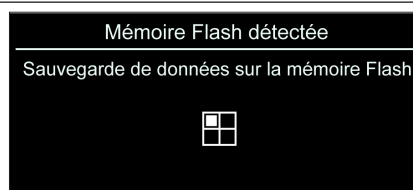

La chaudière est maintenant prête à fonctionner.

13. Vérifiez si l'appareil fonctionne correctement ;

14. Mettez l'habillage en place ;

15. Revissez les 2 vis de verrouillage.

Après des travaux (d'entretien) remontez toujours l'habillage et verrouillez-le à l'aide de vis.

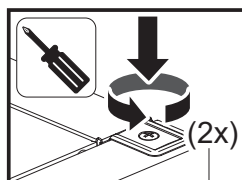

REMARQUE: Si un nouveau Master-PCB est utilisé dans une chaudière produite avant janvier 2021 (jusqu'à P210450459, voir plaque signalétique), veuillez tenir compte des points suivants:

1. **Un blocage de la génération de chaleur et du pressostat gaz sur PADIN 1 est maintenant pour la cascade complète.**

Condition du paramètre: 24.6.4 réglé sur 6 Blocage du générateur de chaleur ou 7 Pressostat à gaz.

Action nécessaire: Si toutes les chaudières en cascade sont équipées d'un pressostat gaz et / ou d'un bloc de génération de chaleur, ceux-ci doivent être retirés sur toutes les chaudières en cas de remplacement de la carte de la chaudière maître. Alternativement, la connexion ne doit pas être établie sur le PADIN 1 mais sur l'un des autres PADIN (2/3/4).

2. **La gestion de la vanne 3 voies en mode ECS (uniquement si chaudière en «mode chaudière») a été modifiée.**

Condition du paramètre: 24.5.3 réglé sur 1 System ballon séparé sonde NTC ou 2 System ballon séparé thermostat.

Action nécessaire: Remplacer les fils L et L1 de la vanne 3 voies.

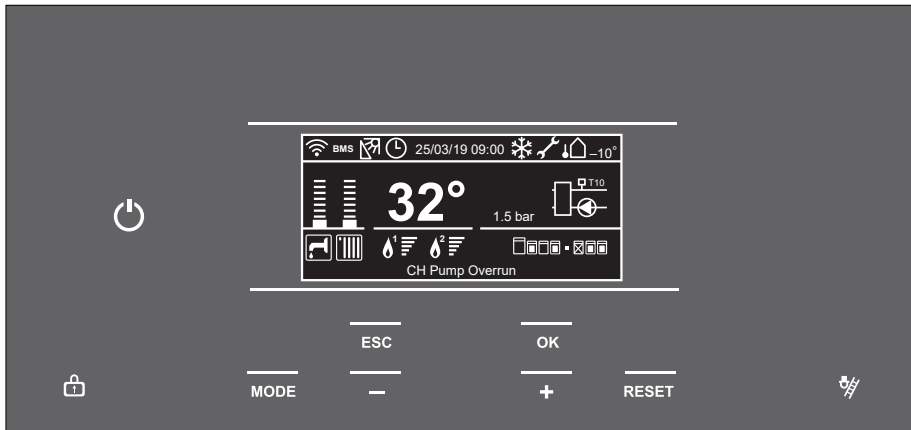

Descrizione delle chiavi

- Tasto di accensione / spegnimento
- Blocca / sblocca lo schermo
- MODE** Modus
- ESC** Esc / Indietro / Correzione
- Diminuisci valore / giù / sinistra
- Aumento di valore / su / destra
- OK** Selezione di conferma
- RESET** Ripristina
- Funzione spazzacamino

7. Inserire l'alimentazione elettrica; All'attivazione della caldaia viene visualizzata una domanda, come riportato nella figura. Dopo aver premuto OK viene visualizzato il menu seguente.

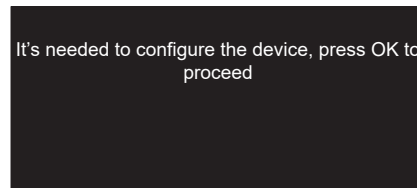

Configurazione di una caldaia singola

Se il sistema non è in cascata, selezionare "Single boiler" (Caldaia singola). Il sistema caricherà automaticamente tutti i parametri necessari per una caldaia singola; se si tratta di un'apparecchiatura a doppio bruciatore, il bruciatore verrà configurato automaticamente.

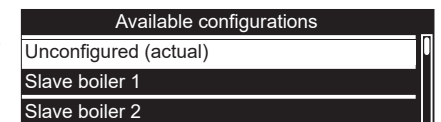
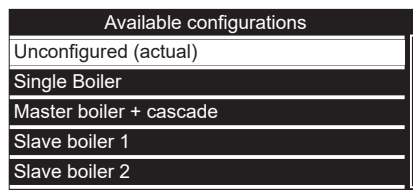

Configurazione in cascata

Se la caldaia fa parte di un impianto in selezionare "Master boiler + cascade" (Caldaia master + cascata) e confermare la selezione premere il pulsante OK. Verrà quindi richiesto di configurare l'apparecchiatura come unità master o slave e di configurarne l'indirizzo.

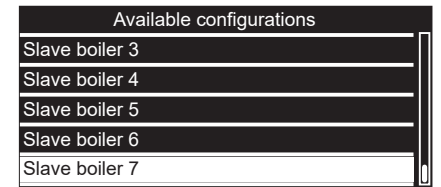
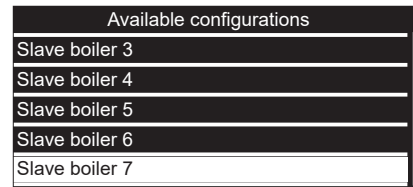

Nel caso siano disponibili tutte le opzioni

Alternativa
Nel caso in cui il Master non sia più disponibile (già configurato in un'altra caldaia)

- Lo schermo visualizza la procedura di start-up:
 - Rilevamento dispositivi
 - Inizializzazione in corso;
- La schermata successiva visualizza la fase di spurgo dell'aria;

Sul display standard: quando è presente un modulo clip-in, il programma di spurgo aria automatico si avvia dopo circa 60 secondi in connessione con l'inizializzazione di eventuali valvole a tre vie collegate.

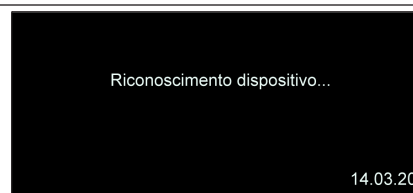

Quando viene posizionata una nuova unità di controllo SLAVE, la caldaia è immediatamente pronta per la messa in servizio.

Quando viene posizionata una nuova unità di controllo MASTER, le impostazioni del display devono essere copiate nella unità di controllo. Segui la procedura successiva:

8. Tenere premuto il pulsante **blocca lo schermo** per 5 secondi.



Viene visualizzato il messaggio:

Nota: scheda madra = unità di controllo
Memoria flash = display

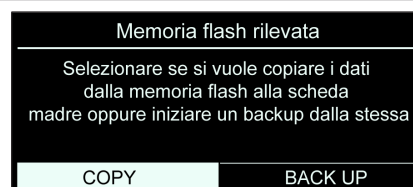

Nota: L'unità di controllo dispone di una "modalità sleep" quando in un certo tempo non è stato toccato alcun tasto. La riattivazione viene eseguita toccando un tasto casuale.

9. Selezionare COPIA premendo il pulsante OK. I parametri vengono copiati e lo schermo mostra:
- Copia dei dati
 - OK
 - Schermata standard;

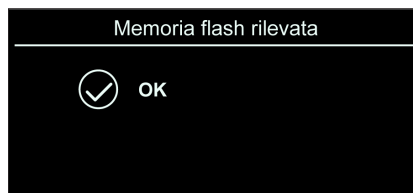
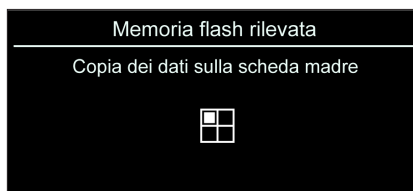

10. Quindi viene automaticamente eseguito il reset della caldaia e lo schermo mostra nuovamente la procedura di start-up:
- Rilevamento dispositivi
 - Inizializzazione in corso;
 - La schermata successiva visualizza la fase di spurgo dell'aria;
- Sul display standard: quando è presente un modulo clip-in, il programma di spurgo aria automatico si avvia dopo circa 60 secondi in connessione con l'inizializzazione di eventuali valvole a tre vie collegate.*

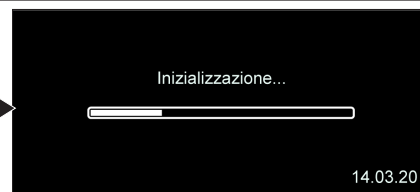
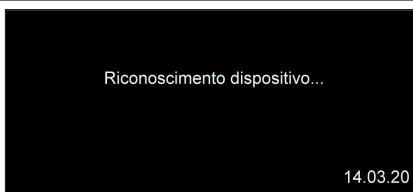

- Viene visualizzato il messaggio:

11. Utilizzando il pulsante +, selezionare BACKUP;

- Viene visualizzato il messaggio:

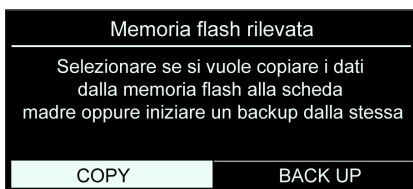

12. Premere il pulsante OK. I parametri vengono ora copiati e lo schermo mostra:
- Backup dei dati
 - OK
 - Schermata standard;

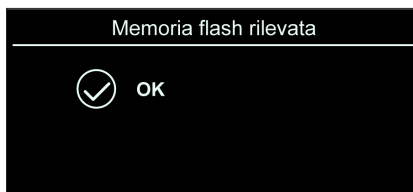
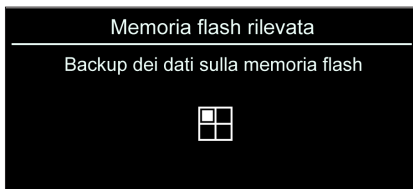

La caldaia è ora pronta per essere messa in funzione.

13. Controllare che la caldaia funzioni regolarmente;



14. Riposizionare la copertura sulla caldaia;
15. Rimontare le 2 viti.

Dopo aver lavorato sulla caldaia, rimettere sempre in posizione la copertura e fissarlo serrando le 2 viti.

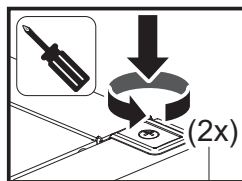

NOTA: Se viene utilizzata una nuova scheda master in una caldaia prodotta prima del gennaio 2021 (fino a P210450459, vedere la targhetta di identificazione), tenere presente quanto segue:

- 1. Un blocco della generazione di calore e Pressostato Gas su PADIN 1 è ora per la cascata completa.**
Condizione parametro: 24.6.4 impostato su 6 generazione di calore bloccata o 7 Pressostato Gas.
Azione necessaria: Nel caso in cui tutte le caldaie in cascata siano dotate di pressostato gas e / o blocco della generazione di calore, questi devono essere rimossi su tutte le caldaie nel caso in cui venga sostituita la scheda sulla caldaia Master. In alternativa il collegamento non deve essere effettuato sul PADIN 1 ma su uno degli altri PADIN (2/3/4).
- 2. Modificata la gestione della valvola a 3 vie in sanitario (solo se caldaia impostata in "modalità caldaia").**
Condizione parametro: 24.5.3 impostato a 1 Accumulo Ext con Sonda NTC o 2 Accumulo Ext con Termostato.
Azione necessaria: scambiare i fili L e L1 della valvola a 3 vie.

操作面板介绍

-  开关键
-  显示锁定/解除锁定
- MODE 模式
- ESC 取消/返回/修正
-  数值减少/降低/向左
-  数值增加/升高/向右
- OK 确认选择
- RESET 重置
-  烟囱吹扫功能

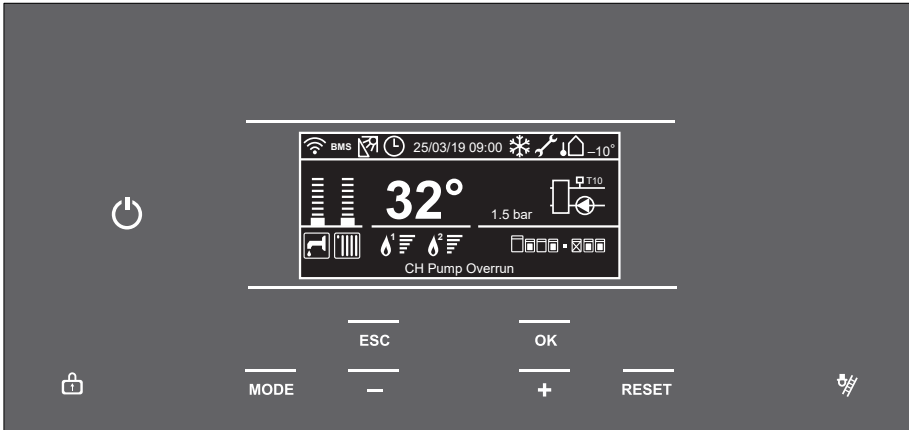

7. 接通主电源;
当一台锅炉被激活时, 就会出现如图所示的问题。
按下OK后显示下一个菜单。

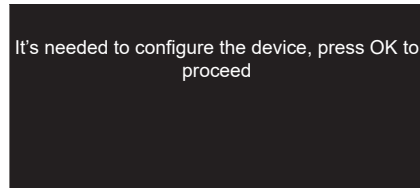

单台锅炉设置

当没有级联时, 选择“Single Boilers”。系统将自动加载单台锅炉所需的所有参数。如果是双燃烧系统设备, 燃烧系统将会自动设定。

级联设置

如果锅炉属于级联安装, 选择“Master boiler + cascade”, 按OK键确认选择。系统将提示您设备配置为主单元或从单元, 并配置地址。

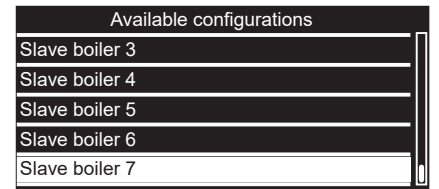
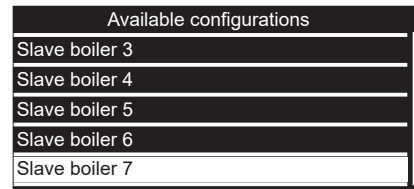
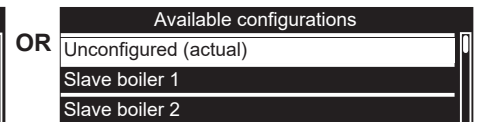
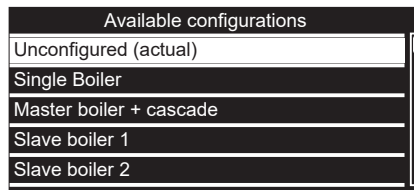

如果所有选项都可用

替代
如果主机不再可用(已经在另一个锅炉中配置)

- 屏幕显示启动过程:

- 发现设备
- 初始化;

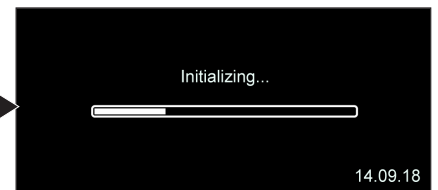

- 屏幕显示其后的自动空气净化程序;
标准显示: 当一个扩展插件存在时, 自动空气净化程序在大约60秒后启动, 用以初始化可能连接的三通阀。

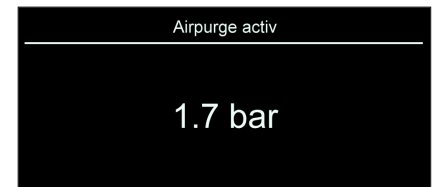

当一个新的从属控制单元被设置完毕时, 锅炉就可以直接投入运行了。

当一个新的主控制单元所显示的设置参数需要复制到控制单元时, 执行下一个程序:

8. 按下显示锁键5秒。

屏幕显示如下:

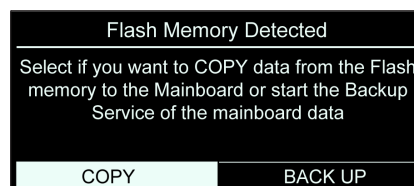

注意: 在一定的时间内没有按键被触摸时, 将会激活控制单元的“睡眠模式”。
触摸一个随机键即可重新激活。

说明: 主板=控制单元
存储器=显示器

9. 按OK键选择COPY。
参数正在被复制，同时屏幕显示：
- 数据复制
 - 确认
 - 标准屏幕；

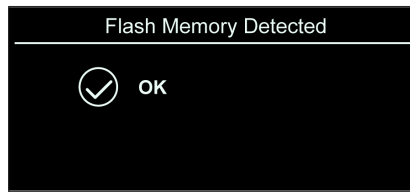
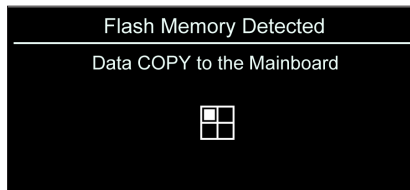

10. 在此之后，锅炉自动复位，屏幕将再次显示启动程序：
- 发现设备
 - 初始化；

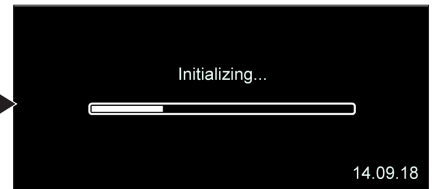

- 其后显示自动空气净化程序；
标准显示:当一个扩展插件存在时，自动空气净化程序在大约60秒后启动，以初始化可能连接的三通阀。



- 屏幕显示：

11. 通过旋转 “+ -” 键选择备份；

- 屏幕显示：

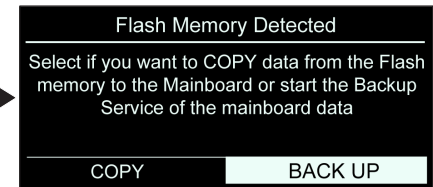
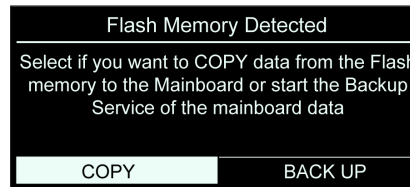

12. 按OK按钮。参数现在被复制回来，屏幕显示：

- 数据备份
- 确认
- 标准屏幕；

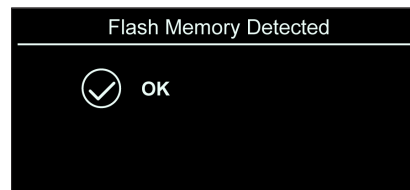
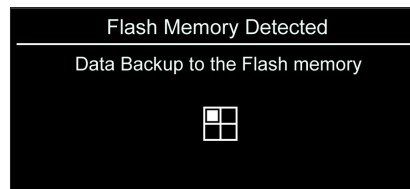

锅炉现在可以投入使用了。

13. 检查锅炉是否正常工作；
14. 将面板装回。
15. 将2颗螺丝装回。

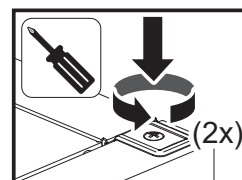

在对锅炉进行操作后，一定要把面板装回，用2个螺丝拧紧。

注意:如果在2021年1月之前(至P210450459, 见铭牌)生产的锅炉中使用了新的主控板, 请注意以下事项::

- PADIN1上的一个压力开关和热需求锁现在用于完成级联。**
参数条件:24.6.4设置为6发热锁或7气体压力开关。
必要措施:如果级联内的所有锅炉都配备了压力开关和/或热需求锁, 在主锅炉上的电路板更换时, 必须拆除所有锅炉上的压力开关和/或热需求锁。作为替代, 连接不应该在PADIN 1上, 而是在另一个PADIN上(2/3/4)。
- 更改了生活热水模式下(仅当锅炉设置为“锅炉模式”时)三通阀的管理。**
参数条件:24.5.3设置为与NTC的 1存储或与温控器的2存储。
必要动作:交换L与L1的三通阀接线。

Par 标准	Factory setting 出厂设置	Value to set 设定值 (China excluded) (除中国外)	Value to set 设定值 (for China) (对于中国)	Value to set 设定值 (for China) (对于中国)
24.3.3-Max pressure 24.3.3-最大压力	6	6 (all)(全部)	3 (for 3900102- 3900108)	4 (for 3900103- 3900109)
26...32.3.3-Max pressure 26...32.3.3-最大压力	6	6 (all)(全部)	3 (for 3900102- 3900108)	4 (for 3900103- 3900109)

